

Serving the road industry since 1975, WRT's focus on quality-built equipment providing a long service life, blended with excellent service, is our foundation for success.

WRT

PT13 & PT15 Pull-Type Pneumatic Tire Rollers



FEATURES

- Low center of gravity ballast compartments provide stability and uniform weight distribution
- Channel formed top edge on body sides
- Gusseted corners provide ultimate ballast body strength
- Rear tow hitch for multiple unit towing
- Drain plug in ballast body
- Removable hinge-type front tow hitch
- Heavy duty bolster assembly with axle support members
- Replaceable maintenance free king pin bushing
- Heavy duty 6-bolt cast steel hubs
- Triple lip seal keeps grease in hub and dirt out
- Wheel pairs oscillate on centre pivot
- Heavy gauge steel wheels
- Smooth, wide-tread compactor tires

WRT's wealth of experience in engineering and manufacturing produces industry leading pull-type pneumatic tire rollers.

- ★ Compact versatility in soil, gravel and asphalt
- ★ Front and rear tires overlap for constant surface contact
- ★ Economical compared to high-priced self-propelled packers
- ★ Tow multiple units with one tractor for maximum compaction – saves time and money

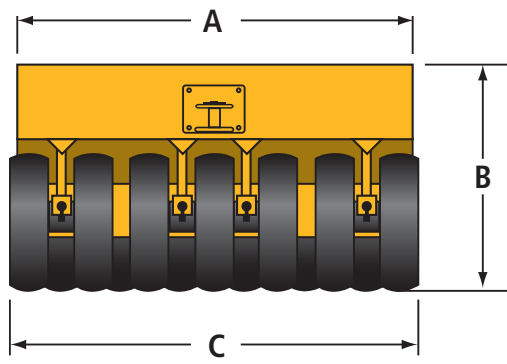

REAR VIEW

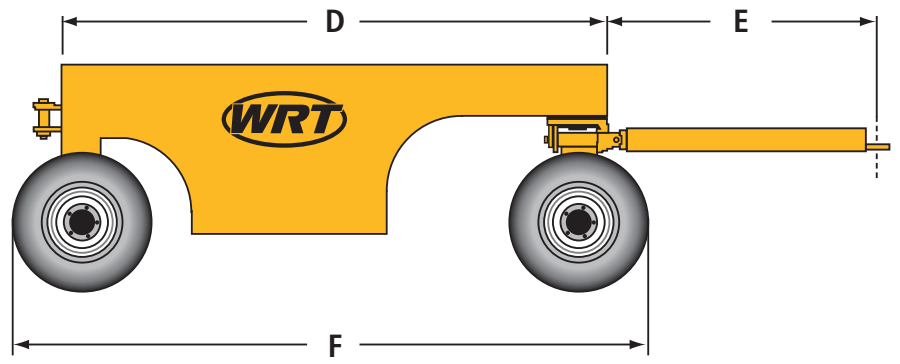

SIDE VIEW

Item	PT-13	PT-15
A Overall Body Width	7' 3½" (2.22 m)	8' ¾" (2.53 m)
B Overall Height	4' 0" (1.22 m)	4' 0" (1.22 m)
C Rolling Width	7' 6" (2.29 m)	8' 6" (2.59 m)
D Ballast Length	10' 0" (3.05 m)	10' 7" (3.23 m)
E Ballast to Hitch Center	4' 9½" (1.46 m)	5' 7¾" (1.71 m)
F Overall Length Hitch Removed	11' 6½" (3.52 m)	12' 1½" (3.70 m)
Number of Wheels	13 (6 on front, 7 on rear)	15 (7 on front, 8 on rear)
Wheel Base	109½" (278 cm)	116½" (296 cm)
Ballast Capacity	120 cu. ft. (3.40 cu. m)	140 cu. ft. (3.96 cu. m)
Shipping Weight	4,250 lbs. (1,930 kg)	4,665 lbs. (2,115 kg)
Shipping Weight (with optional foam filled tires)	5,745 lbs. (2,605 kg)	6,390 lbs. (2,900 kg)
Wheels	15 x 6	15 x 6

NOTE: The supplied and recommended tire pressure is 40 psi. Other tire pressures up to 60 psi can be used to vary compaction results as indicated in the table below.

COMPACTION DATA

(8.50 x 15, 6 Ply, Smooth Wide Tread Compactor Tires)

WHEEL LOAD	GCP *GCP=Wheel Load Footprint Area psi (kPa)	PUW **PUW=Wheel Load Tire Width lbs./in. (kg/cm)	TIRE PRESSURE psi
1000 lbs. (454 kg)	37 (255)	175 (31.3)	35
	39 (269)	181 (32.3)	40
	44 (303)	192 (34.3)	50
	49 (338)	204 (36.4)	60
1500 lbs. (680 kg)	40 (276)	222 (39.6)	35
	42 (290)	227 (40.5)	40
	47 (324)	237 (42.3)	50
	52 (359)	250 (44.6)	60
2000 lbs. (907 kg)	43 (296)	274 (48.8)	35
	45 (310)	277 (49.4)	40
	50 (345)	286 (51.1)	50
	55 (379)	299 (53.4)	60

* GCP (Ground Compact Pressure) is a measure of the pressure acting on the footprint area of the tire.

** PUW (Pressure Per Unit of Tire Contact Width) is a measure of the force acting on each inch of tire width.

DISTRIBUTED BY: